

## 9700 SERIES VIDEO INSPECTION SYSTEM

The 9700 Series Video Inspection System is our largest heavy-duty model adopted from the S-T Industries optical division acquisition.

### FEATURES

- LED profile and surface lighting
- High Precision 12" x 12" travel measuring stages with 0.1(one tenth) micron scales standard resolution precision scales with quick release on X and Y axis
- Integrated granite base and column
- High-resolution 30X to 180X Par Focus zoom optics
- Digital crosshair generator with automatic edge indicator
- 6 " Focus travel with optional Z-axis measuring scales
- Metlogix Software
- Optional 2-axis or 3-axis Motor Controls
- Optional full CNC 3-axis controls with Auto Focus, video edge detection and programmable lighting with joystick and trackball controls and fine adjust knobs allowing movements to .00005"/.001 mm

### DIMENSIONS

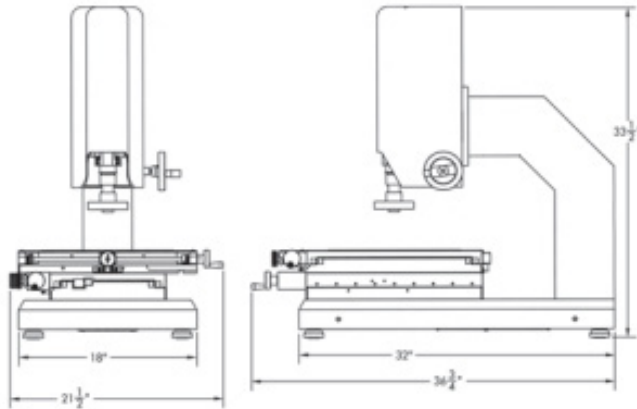

Technical Specification	
Work Table:	18" x 18" - Black Anodized
Measuring Range:	(X)--12" (Y)--12" (Z)--6"
Allowable Work Load:	25 lb
Illumination:	Profile - LED Surface - LED
Magnification Lens:	30-180X Parfocal Zoom
Power Requirements	100-240 V, 50/60 Hz Compatible
Weight	Manual 455 lb Crated 500 lb CNC 515 lb Crated 560 lb

