

S4 COMPARATOR HEIGHT STAND

The Dorsey S4 height stand is designed for making comparative height measurements. It is designed primarily for transfer measurements on a surface plate but the optional anvil also permits its use as a conventional comparator stand.

This stand will accommodate mechanical, electronic, digital or pneumatic probes with a standard mounting lug. The Model S4 stand can be adjusted vertically, horizontally and radially to adapt to any height gaging situation.

FEATURES:

- Fine adjustment base -- original frictionless reed spring mechanism assures "no tilt" vertical adjustment of the column
- Wide fine adjustment range -- total .19" range permits more rapid gaging setup
- Interchangeable columns -- sturdy chrome plated steel columns, 12", 18" and 24" are easily interchangeable in the field to meet various height measuring requirements
- Triangular support -- three precision flats on base assure stability of gaging set up when transferring height measurements on surface plate
- Positive clamping design -- split bushing clamping arrangement provides positive locking on cross arm assembly
- Optional anvil -- provisions in base for field installation of optional hardened and lapped steel anvil increases versatility of the stand

ORDERING INFORMATION	PART #
S4 Stand with 12" column	49451
S4 Stand with 18" column	49456
S4 Stand with 24" column	49457
OPTIONAL 2" diameter anvil	49472

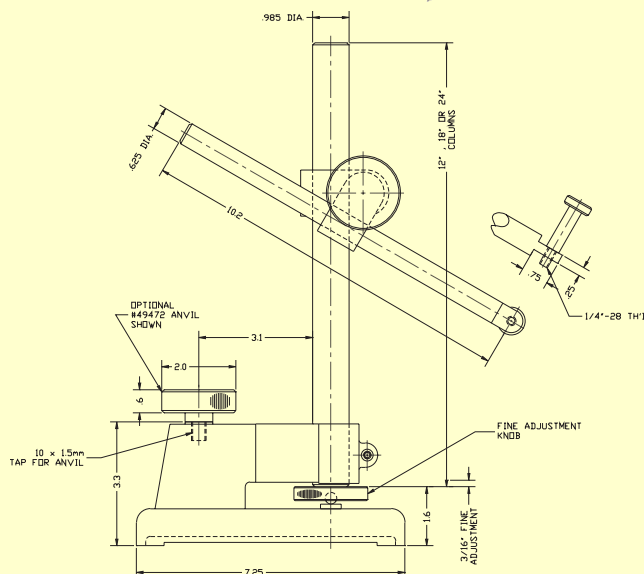

The Fine Adjustment Base
 By rotating the adjustment wheel, the column is raised or lowered. Motion parallel to the longitudinal axis of the column is maintained by the reed-spring assembly. Downward pressure on the wheel is sustained by the coil spring preventing backlash and drift.

Proudly made in the USA

