

ULTRA HIGH AMPLIFICATION GROUP 4

20 Millionths that you can actually read!

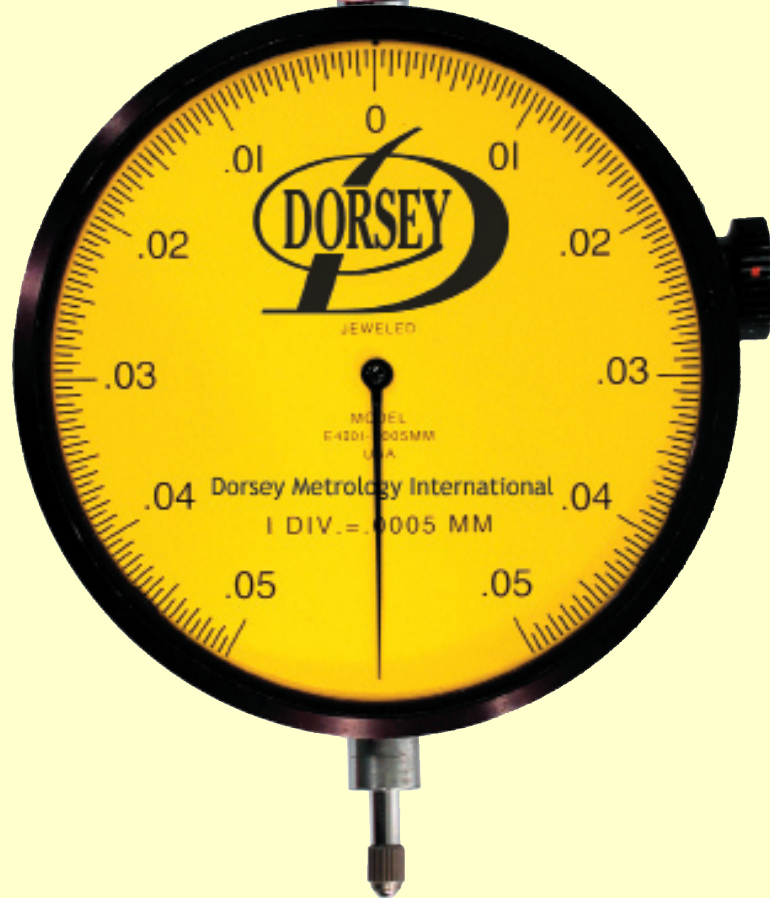

FEATURES:

- High amplification movement permits:
 - Graduations as fine as 0.00002".
 - Improved readability and minimized judgement error.
 - Performance comparable to more expensive gaging methods.
 - Convenient portability - no external connections required.
 - Interchangeability - can be used in the same environment as any other mechanical dial indicator.
 - Simplified service - complete movement is easily removed from the case for cleaning or direct replacement at low cost.
- Lever principle of amplification - minimizes effect of spindle sideshake. Linearity and repeatability maintained through millions of cycles.
- 3-5/8" bezel - conforms to ANSI/AGD standards.
- Adjustable gaging force - easily adjustable from 2 to 5 oz. by externally accessible screw.
- External zero adjustment knob - makes possible the advantage of adjusting indicator hand to zero rather than rotating bezel to 'zero' hand.
- Optional lifting lever or cable release. Use lifting lever only when indicator is back mounted. Cable release may be used when indicator is back or stem mounted and enhanced stability of gaging setup.

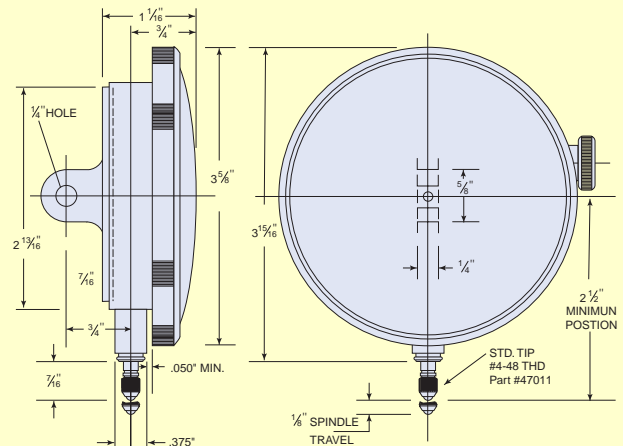

See page A-12 for dial face options, A-13 for accessories & contacts and A-4 for back options

Proudly made in the USA

